

TP 130 MOBILE

Wood chipper on trailer with own engine.

The characteristic of the new wood chipper is the wish to optimize on price without compromising on quality. TP 130 has one hydraulic driven feed roller which is manufactured with tooth feeder made from wear steel which gives a strong and aggressive infeed when the wood is fed through the hopper and directly to the knives. The chips that are produced are 8 mm long and very uniform as the wood is cut at an angle of 90 degrees. In terms of safety the machine complies with current regulations in the EU. The wood chipper is equipped with an operation bar for controlling the feed roller. With the operation bar it is possible for the operator to start and stop as well as reverse of the feed roller.

Standard on TP 130 MOBILE

- Integrated hydraulic system
- Two knives
- Two counter steels in Raex 400
- Simple knife fitting without adjustment
- One hydraulic driven feed roller
- Turnable ejector spout
- Wipers to avoid accumulation of material by the feed rollers and the rotor housing
- Rotor lock to secure rotor disc at knife change
- Operation bar for start/stop/reverse of feed rollers
- TP PILOT stress control system with hour counter
- Kohler 25 hp petrol motor
- Petrol tank in plastic
- Extensive manual with spare parts catalogue
- All wearing parts can be changed with standard tools



TP 100

TP 130

TP 160

TP 200

TP 250

TP 230

TP 270

TP 280

TP 400

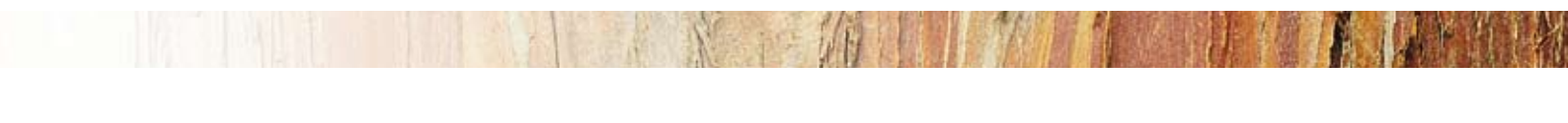

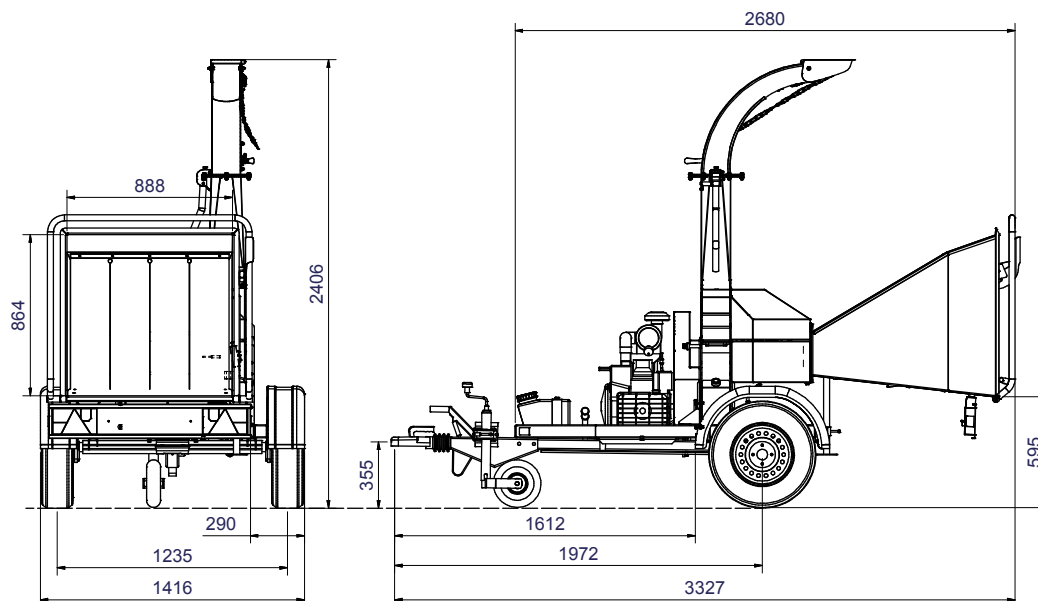

TECHNICAL DATA

Max. wood diameter	130 mm
Max. opening of rollers	H x B = 130 x 220 mm
Operation	Return/forward/stop of feed rollers through operation bar (yellow)
Chipper principle	Disc
cutting angle	90°
Feeding angle	Parallel to driving direction
Infeed	1 hydraulic feed roller, spring compressed of 18 mm spring
Feed roller	Horizontal
Rotor disc - diameter	660 mm
Rotor disc - weight in kg	85
Numer of knives	2 pcs.
Chip length	8 mm
Counter steel	1 horizontal and 1 vertical
Motor	Kohler, 2 cylinder petrol, 18 kW (25 hp)
Transmission	Manual coupling system
Stress control system - TP PILOT	Including hour counter
Fuel consumption	5 liters/hour (experience no.)
Tank volume	24 liters
Trailer	One axlet trailer (80 km/h) with drawbar and breaks, glavanized. It comes with a 13 pole plug for light system
Chip capacity	3-6 m ³ /hour
Weight	660 kg

ACCESSORIES

Extended ejector spout	500 mm vertical - 1.000 mm horizontal
Lock	Lock which can be mounted over the trailer hitch
Tool set	Includes tools for daily service and maintenance
Sliver breakers	Type A, with 4 fingers
Guard in rotor housing	Recommended if the wish is to make uniform chips