

# TP 160 TRACK

Wood chipper on tracks with own motor.

Elegant and efficient wood chipper with hydraulic intake for chipping of branches of up to 160 mm in diameter. The integrated hydraulic system and the 2 horizontal cylinders ensure a strong and problem-free intake.

TP 160 is a disc cutter where the wood is cut at an angle of 90 degrees. The heart of the machine is the two knives and the two anvils that ensure efficient wood chipping and a nice uniform chip quality.

The new design, increased capacity and improved service conditions make the TP 160 an attractive wood chipper and show that even a small machine can be used professionally.

## Standard on TP 160

- Integrated hydraulic system
- Two knives
- Two anvils in Raex 400
- Simple knife fitting without adjustment
- Two hydraulically powered intake cylinders
- Powerful spring to hold against moving cylinder
- Turnable ejector tube
- Scrapers to secure against accumulation of material at the intake cylinders and in the rotor house
- Hydraulic adjustment of the cylinder speed
- Rotor lock to secure rotor disc at knife change
- Operation bar for start/stop/reverse of the intake cylinders
- TP PILOT Revolution guard with hour counter
- All wearing parts can be changed with standard tools
- Extensive manual with spare parts catalogue

## New initiatives:

- New elegant design
- 10 mm chip size
- Unencumbered access to anvil
- Improved chip quality because of the cylinders location in relation to the rotor house
- More powerful intake
- New automatic coupling system
- Easy access to motor room



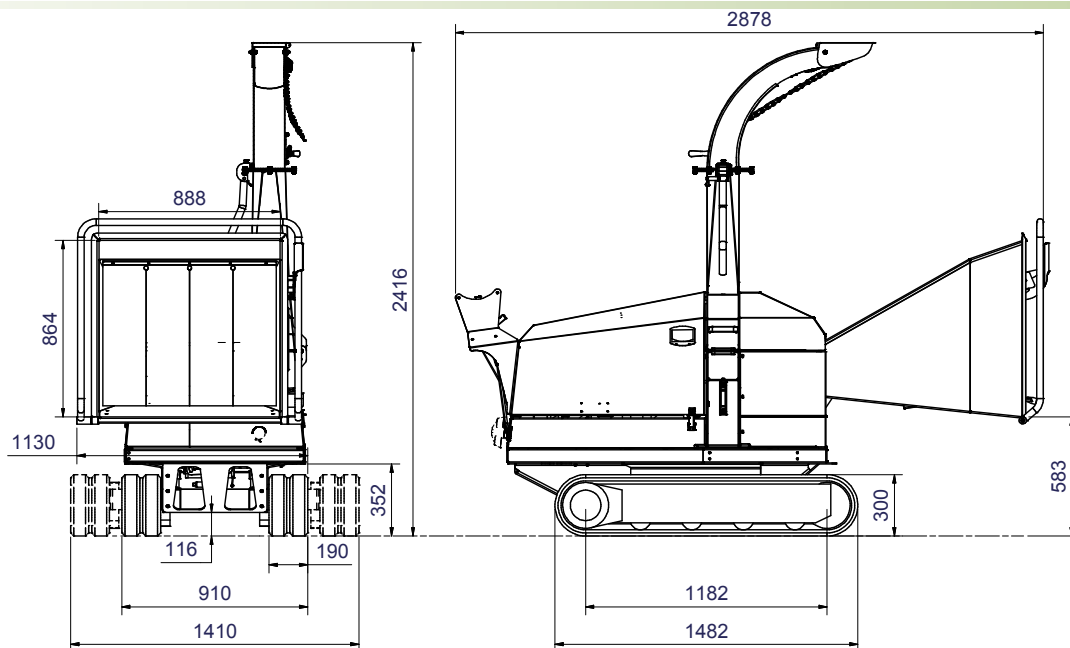

## TECHNICAL DATA

<b>Max wood diameter</b>	<b>160 mm</b>
<b>Max opening at feed rollers</b>	<b>H x B = 160 x 220 mm</b>
<b>Operation</b>	<b>Return/forward/Stop of feed rollers through operating bar (yellow)</b>
<b>Chipper principle</b>	<b>Disc</b>
<b>Feeding angle</b>	<b>90°</b>
<b>Feeding angle</b>	<b>Parallel to driving direction</b>
<b>In feed</b>	<b>2 hydraulic feed rollers. spring compressed of 1 spring 8mm</b>
<b>Feed rollers</b>	<b>Horisontal</b>
<b>Rotor disc - diameter</b>	<b>660 mm</b>
<b>Rotor disc - Weight in kg</b>	<b>85</b>
<b>Number of knives</b>	<b>2 pcs.</b>
<b>Chip length</b>	<b>Up to 10 mm (hydraulic ajustable)</b>
<b>Anvil/counter steel</b>	<b>1 horizontal and 1 vertical</b>
<b>Motor</b>	<b>Lombardini 4 cyl. watercooled with 26 kW/ 35 hp</b>
<b>Transmission</b>	<b>Automatic coupling system</b>
<b>Indicator and stop of motor by:</b>	<b>Too low oil pressure and too high temperature on cooling system</b>
<b>Stress control - TP PILOT</b>	<b>Including hour counter</b>
<b>Fuel consumption</b>	<b>3,5 liter/hour (Experience number)</b>
<b>Tank volume</b>	<b>20 liter</b>
<b>Tracks</b>	<b>Two speeds</b>
<b>Chip capacity</b>	<b>5-10 m<sup>3</sup>/hour (Experience numbers by manual operation)</b>
<b>Weight</b>	<b>1.195</b>

## ACCESSORIES

<b>Extended ejector spout</b>	<b>500 mm vertical - 1.000 mm horisontal</b>
<b>Tool set</b>	<b>Includes tools for daily service and maintenance</b>
<b>Sliver breakers</b>	<b>Type A with 4 fingers</b>