

TP 200 MOBILE TURNTABLE

All-round wood chipper mounted on a trailer with turntable and own engine.

This is not without reason the most sold model of the TP Wood chippers. Functionality and flexibility have been crucial factors for many buyers. The TP 200 is a disc chipper with hydraulic feed, three knives and three anvils. Simple, flexible and effective for wood chipping of branches and entire trees up to 200 mm in diameter. The wood is carried by two hydraulically powered feed rollers and cut at an angle of 90 degrees.

Standard on TP 200

- Integrated hydraulics system
- Three knives
- Three anvils in Raex 400
- Two hydraulically powered feed rollers which ensure a powerful feeding
- Powerful tension spring on moving rollers
- Revolving ejector spout
- Wipers to ensure against accumulation of material at feed rollers and rotor housing
- Changeable casing in rotor housing
- Hydraulic adjustment of the roller speed and thereby the chip size
- Rotor lock for securing the rotor disc when changing knives
- Operating bar start/stop/reversing of the feed rollers
- Danfoss Hydraulic engines
- Comprehensive manual with complete spare parts list
- Tip up funnel
- Stress control system - TP PILOT



TP 100

TP 130

TP 160

TP 200

TP 250

TP 230

TP 270

TP 280

TP 400

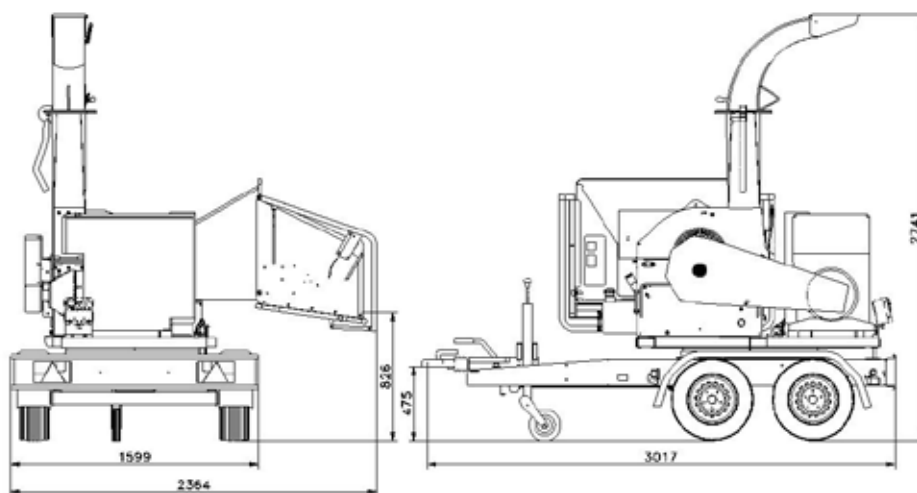

TECHNICAL DATA

Max wood diameter	200 mm
Max opening	H x W = 210 x 265 mm
Operation	Return/forward/stop of feed rollers through operating bar (yellow)
Chipper principle	Disc
Chipping angle	90°
In feed angle	Depends on the turntables position
In feed	2 hydraulic feed rollers, spring compressed of 1 spring 8 mm
Feed rollers	Horisontal
Rotordisc - diameter	760 mm with changeable end sections on ejector wings
Rotordisc - Weight in kg	168
Number of knives	3 pcs.
Chip lenght	4 - 10 mm (hydraulic ajustable)
Anvil/Counter steel	1 horisontal and 2 vertical
Engine	Hatz Silent Pack, 3 cylinders aircooled diesel with 52 hp
Transmission	Manuel clutch between V-belt of rotor and engine
Indicator and stop of engine	Too low oil pressure and too high temperature on coolingsystem
Fuel consumption	52 hp: 4 liters/h (experience numbers)
Tank volume	47 liters
Trailer	One axlet trailer (80 km/h) with drawbar and support wheel, galvanized
Chip capacity	6-12 m ³ /hour
Weight	1550 kg (52 hp) • 1625 (72 hp)

EXTRA EQUIPMENT

Extended ejector spout	500 mm vertical • 335 mm vertical • 1.500 mm horisontal
Tip-up ejector spout	
Sliverbreakers	Type A or B - are used if extra requirements for chip quality is needed
Trailer lock	Lock which can be mounted over the trailers hitch
Tool kit	Includes tools for daily service and maintenance